



PETROL POST DRIVER™

Australian Engineering by Christie

SAFETY, OPERATION & MAINTENANCE INSTRUCTIONS

MODEL - CHPD78-1

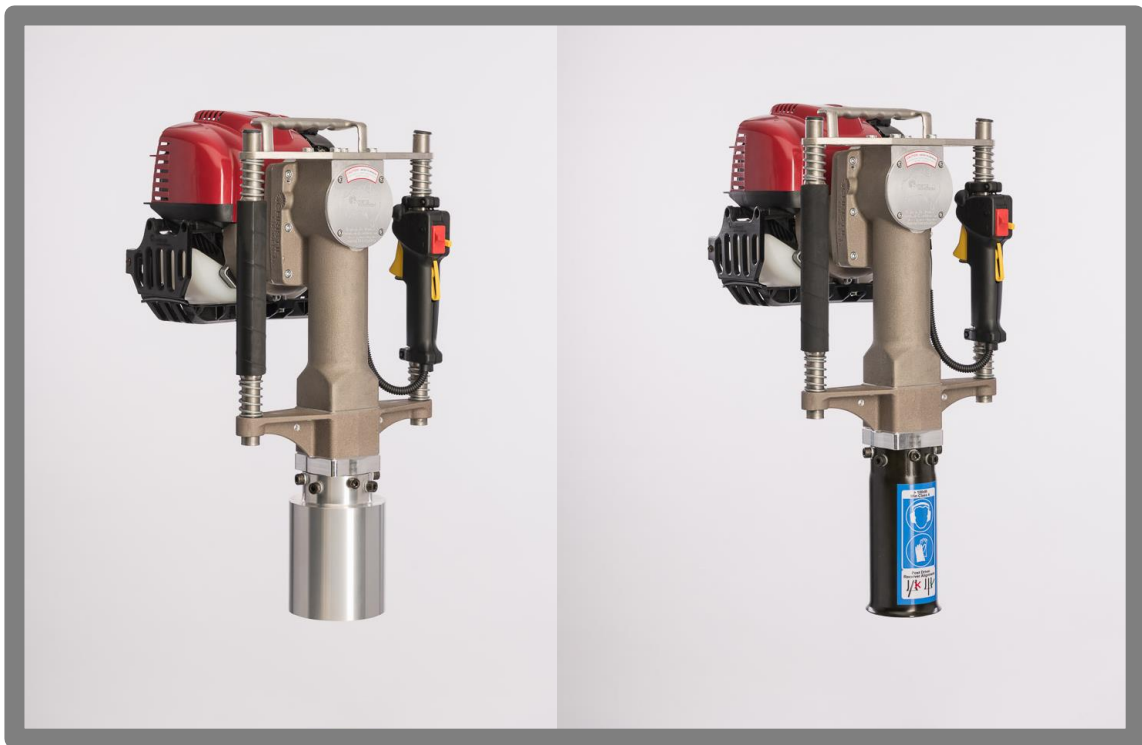

SN 3950 +



ENGLISH

SAFETY, OPERATING & MAINTENANCE INSTRUCTIONS



Thank you for purchasing the **Easy Petrol Post Driver**. We are proud of the quality engineering and construction of this product and hope that you will enjoy many years of productive use from your machine.



Christie Engineering Pty Ltd are a family owned and operated Australian business. They are the designers and manufacturers of the very first petrol engine driven post driver on the market.

Easy Petrol Post Driver are proud to work with them as the sole distributors of their Post Drivers throughout Europe.

For more information please visit:

www.christieengineering.com.au

www.petrolpostdriver.com



Read these instructions carefully and understand all safety and operating instructions prior to using the machine. The Instructions contain essential safety information and provide knowledge on how use and maintain the machine in a safe and efficient way.



Read these instructions in conjunction with the supplied Honda Owner's Manual GX35. This manual also contains important safety information and engine maintenance information.

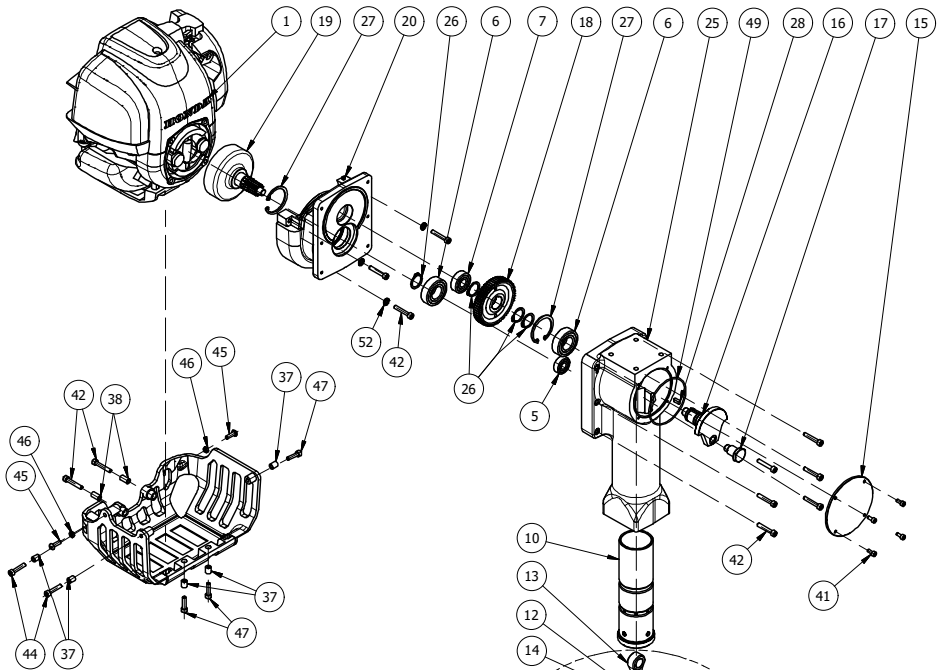

DETAIL A
SCALE 1/6

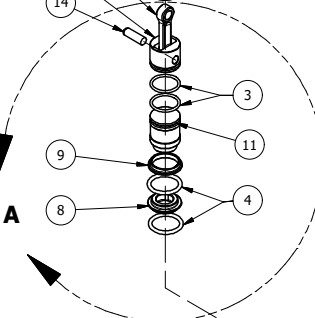
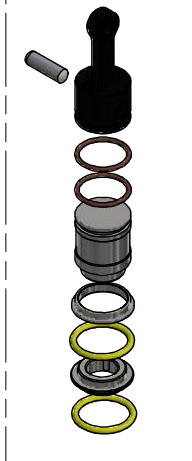

CHPD 78-1 PARTS LIST: SN 3950+

ITEM	QTY	PART NUMBER	DESCRIPTION
1	1	GX35	HONDA MOTOR
2	1	17850VL1741	THROTTLE LEVER ASSEMBLY
3	2	CEPD BS222	O RING
4	2	CEPD BS326	DAMPER O RING
5	1	CEPD 6000-2RS	DEEP GROOVE BALL BEARINGS
6	2	CEPD 6004-2RS	DEEP GROOVE BALL BEARINGS
7	1	CEPD 6201-2RS	DEEP GROOVE BALL BEARINGS
8	1	CEPD 20	HAMMER GUIDE
9	1	CEPD 22	DAMPER WASHER
10	1	CEPD 24-1	STEEL CYLINDER LINER
11	1	CEPD 27	TOP HAMMER
12	1	CEPD 30	PISTON
13	1	CEPD 31	CONNECTING ROD
14	1	CEPD 31-A	GUDGEON PIN 12 x 40
15	1	CEPD 37	COVER PLATE
16	1	CEPD 38	CRANK SHAFT
17	1	CEPD 38 PIN	CRANK PIN LH S1214
18	1	CEPD 54-58	58T DRIVEN GEAR
19	1	CEPD 60-13	CLUTCH DRUM
20	1	CEPD 67-2	CAST CLUTCH HOUSING
21	1	CEPD 920	HANDLE MOUNT TOP BRACKET
22	4	CEPD 921-S	SPRING
23	1	CEPD 921-A	HANDLE RUBBER
24	2	CEPD 922	HANDLEBAR
25	1	CEPD 924	CRANK HOUSING
26	4	CEPD CC 20x1.20	EXTERNAL CIRCLIP
27	2	CEPD CC 42x1.75	INTERNAL CIRCLIP
28	1	CEPD A4x4x12	PARALLEL KEY
29	1	CEPD 925	CAST BOTTOM HOUSING
30	1	CEPD BS220	O RING
31	1	CEPD 936-1	HAMMER HOUSING (CEPD 78)
32	1	CEPD 937	3rd HAMMER (CEPD 78)
33	1	CEPD 934	BOTTOM GUIDE TUBE (CEPD 78)
34	1	CEPD 938-1	FLANGED ADAPTER (CEPD 78)
35	1	CEPD 930	REDUCER 78-54 mm
36	1	CEPD GUARD	CEPD GUARD
37	5	CEPD SPACER 8x5x10	SPACER 8x5x10
38	2	CEPD SPACER 8x5x14	SPACER 8x5x14
39	2	CEPD BS334	REDUCER O RING
40	12	CEPD M816 SHCS (M818)	M8 x 16 SHCS (M8x18)
41	4	CEPD M410 SHCS	M4 x 10 SHCS
42	11	CEPD M530 SHCS	M5 x 30 SHCS
43	4	CEPD M880 SHCS	M8 x 80 SHCS
44	2	CEPD M525 SHCS	M5 x 25 SHCS
45	2	CEPD M516 BHCS	M5 x 16 BHCS
46	2	CEPD M5 HEX NUT	M5 HEX NUT
47	3	CEPD M520 SHCS	M5 x 20 SHCS
48	2	CEPD PIN 8x36	PIN 8 x 36
49	1	CEPD BS040	O RING
50	2	CEPD BS035	O RING
51	1	CEPD DAMPER 3MM	PU FLAT WASHER
52	3	CEPD M5 WASHER	FLAT WASHER 10.9 x 5.7 x 1.3

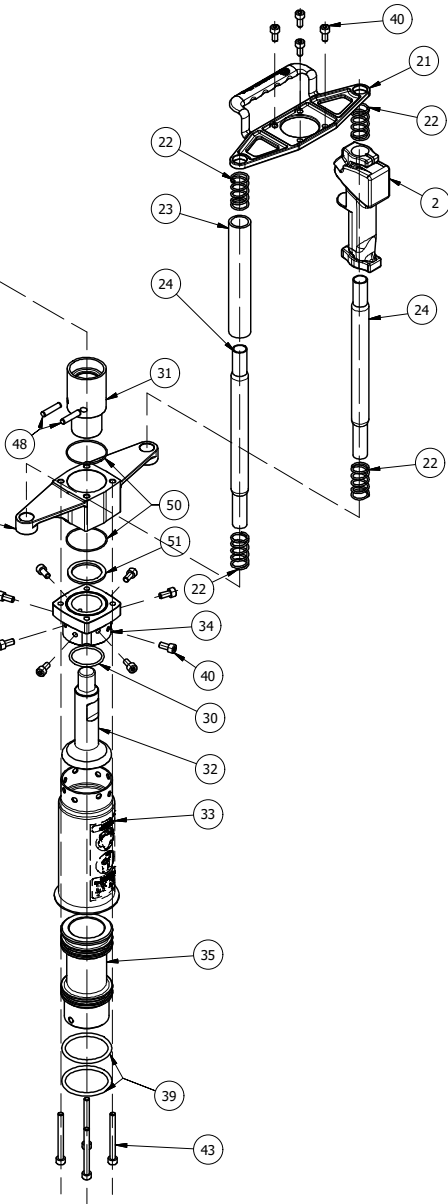

Table of contents

POINTS OF CAUTION	1
DRY FIRING	1
BOLT TIGHTENING	1
ENGINE OIL LEVELS & FUEL USE	1
SAFETY	2
UNEXPECTED MOVEMENT	2
PERSONAL PROTECTIVE EQUIPMENT (PPE)	2
NOISE HAZARD	2
ELECTRICAL/CONCEALED OBJECT HAZARDS	2
VIBRATION HAZARD	3
SERVICE AND MAINTENANCE	3
SMALLER POSTS - USE OF ADAPTERS	4
TALL POSTS	4
SPECIFICATION AND APPLICATIONS	5
DESIGN AND FUNCTION	5
SPECIFICATION	5
APPLICATIONS	6
OPERATING INSTRUCTIONS	7
PRE-START CHECKLIST	7
SAFE STARTING	7
DRIVING POSTS	8
MAXIMUM OPERATING CONDITIONS	9
MAINTENANCE AND SERVICING	10
MAINTENANCE SCHEDULE	10
END USER SERVICING	10
MANUFACTURER SERVICING	10
CRANK LUBRICATION SERVICE	11
HAMMER SECTION SERVICE	12
TROUBLESHOOTING AND FAQ	15
TROUBLESHOOTING	15
FREQUENTLY ASKED QUESTIONS (FAQ)	16
EASY PETROL POST DRIVER WARRANTY	17
CONDITIONS	17
EXCLUSIONS	17
HOW TO MAKE A CLAIM:	18
HONDA WARRANTY	19
CONDITIONS	19
EXCLUSIONS	19
HOW TO MAKE A CLAIM	19
HONDA FUEL ADVICE	21
DISTRIBUTOR NETWORK	22

Points of caution

This machine operates using a Honda GX35T, 4 Stroke Engine. Read both manuals **thoroughly before** operation. **IMPORTANT:** Warranty will not be valid if operating methods are not followed. In particular please note the following points of caution:

Dry Firing



ONLY operate the throttle while the Christie Post Driver is on a post and between 10-15kg pull down force is exerted on the handles. Pressing the throttle without load is known as 'dry firing'.

Failure to follow this instruction can result in danger to the operator and damage to the machine.

Further, never drive a post/rod in to the ground until the receiver barrel touches the ground as this can result damage to the post driver.

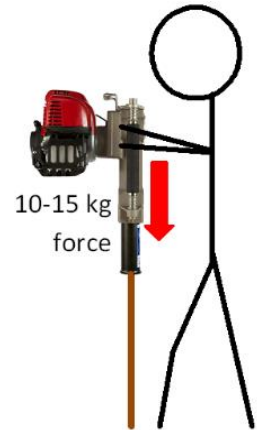

Bolt Tightening



As a vibrating machine, bolts will on occasion require re-tightening. Visually inspect all fasteners as part of your Pre-Start Checks (see pg7). If bolts repeatedly come loose; remove bolt entirely, clean both machine thread and bolt thread with degreaser/solvent, apply Oil Tolerant Locking Compound & re-affix the bolt.

Engine Oil Levels & Fuel Use



ENGINE OIL – Your machine is delivered with engine oil inside. Carefully monitor the oil levels of the Honda GX35T engine, especially over your first few uses.

- Stand the driver & machine upright.
- Fill oil level up to the edge of the screw thread, as if just about to overflow. DO NOT lay the engine on its side to fill, this will over-fill the engine.

Oil Specification; 10W30 mineral engine oil.

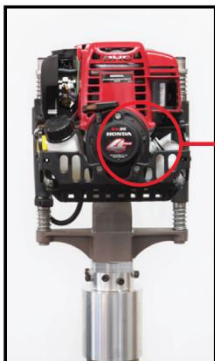

Unscrew cap and fill oil to this point

Check oil level regularly. Refer also to the 'Troubleshooting' section of this manual. Damage caused by failure to maintain oil level is not covered by the warranty.



FUEL – Use Regular Unleaded Petrol.

If your Post Driver use will be intermittent (e.g. more than 4 weeks between use) either use a fuel stabiliser, or drain the fuel tank and carburettor between uses. Use fresh, clean Petrol. Petrol will start to deteriorate if stored for more than 1 month. Also see Page 21, and the Honda Manual for further information.

Safety

This section provides safety information and hazards of a general nature. Further safety warnings and information are provided where relevant, in the *Operating Instructions*, and *Maintenance and servicing* sections of this document.

Unexpected movement



Warning: Sudden or unexpected movement of the machine may occur during operation, which may result in injury to the operator and/or damage to the machine.



- Ensure the operator maintains a stable standing position with feet shoulders width apart. Keep body weight balanced.
- Stand firmly and always hold the Post Driver with both hands.
- Operate the Post Driver with both feet in contact with the ground. Never stand on a ladder, chair, trailer, ute/pickup tray, or any other surface other than stable ground.
- Ensure the handles are free from grease and oil.
- Start the engine with the Post Driver upright. Do not start the Post Driver with it lying on the ground.

Personal Protective Equipment (PPE)

Ensure the operator and all other persons nearby wear, at a minimum, the following PPE:

- Class 4 hearing protection, greater than 22dB attenuation
- Safety glasses to AS/NZS1337 medium impact rating
- Gloves suited to manual handling - leather or other abrasion resistant material, anti-vibration gloves are recommended
- Steel capped boots



Noise hazard



High sound levels may cause permanent hearing loss. Noise emitted from the tool while working can reach above 100dB which can also harm others nearby, both the operator and bystanders are to wear Class 4 hearing protection greater than 22dB attenuation.

Electrical/concealed object hazards



Whilst driving posts, concealed electrical services, wires and pipes constitute a danger that can result in serious injury or death. Before you start using the tool, check the composition of the material you are to work on. Identify and avoid concealed cables and pipes e.g. electricity, telephone, water, gas and sewage lines etc.

If the tool seems to have hit a concealed object, switch off the machine immediately. Make sure that there is no danger before continuing.

Vibration hazard

Hand-arm vibration (HAV)

Vibration levels	9.24 m/s ² (Data from 100mm diameter wooden post)
-------------------------	---

Exposure to HAV can result in disrupted circulation in the hand and forearm and/or damage to nerves and tendons, muscles, bones and joints of the hand and arm. It can cause a range of conditions collectively known as hand–arm vibration syndrome (HAVS) and specific disorders such as carpal tunnel syndrome, ‘tennis elbow’ and ‘vibration white finger’. Workers with exposure to vibration while performing other hazardous manual tasks may also experience pain in the hands and arms and diminished muscle strength.

Reducing the risk of hand-arm vibration

Normal use of the Easy Petrol Post Driver exposes the operator to vibration. Vibrations from handheld machines are transmitted into the hands via the handles. The spring dampened handles on the Easy Petrol Post Driver are designed to dampen a large part of the initial vibrations. Further measures are required as vibrations are not eliminated completely.

- Christie Engineering & Easy Petrol Post Driver recommends operators/employers implement a program of health surveillance to detect early symptoms that may relate to vibration exposure, so that management procedures can be modified to help prevent significant disability.
- If numbness, tingling, pain, clumsiness, weakened grip, whitening of the skin, or other symptoms occur at any time, when operating the machine or when not operating the machine, do not resume operating the machine and seek medical attention.
- Let the tool do the job. Use a firm, but minimum hand grip, consistent with proper control and safe operation.
- When the impact mechanism is activated, the only body contact with the Post Driver should be hands on the spring dampened handles. Avoid any other contact, e.g. supporting any part of the body against the machine or leaning onto the machine trying to increase the feed force.
- Never keep the trigger engaged while removing the Post Driver from the post.
- Immediately stop working if the machine suddenly starts to vibrate strongly. Before resuming the work, find and remedy the cause of the increased vibrations.

Service and Maintenance



Read these Safety and Operating Instructions carefully and ensure maintenance and servicing are completed according with requirements. Perform engine maintenance in accordance with the supplied Honda Owner's Manual GX35.

- Regular maintenance is a prerequisite for keeping the machine safe and effective.
- If parts are damaged or worn, immediately cease using the Post Driver until they have been serviced or replaced.
- Replace worn components in good time. When cleaning mechanical parts with solvent, make sure to comply with occupational health and safety regulations, and make sure that there is satisfactory ventilation. Ensure PPE such as respiratory mask, gloves, and safety glasses are worn, and the manufacturer supplied Safety Data Sheet (SDS) for the solvent used is read and understood.

Smaller posts - use of adapters



Warning: Driving posts which are significantly smaller than the receiver barrel will result in instability while operating the Post Driver. It will also affect the efficiency of the Post Driver. This may result in injury to the operator and will result in damage to Post Driver.



Solution: Ensure there is a maximum clearance of 10mm between POST and ADAPTER (5mm each side). If the clearance between POST and ADAPTER is greater than 10mm use an adapter to suit your post size.

For more information on our adapters please contact us, or visit our website

www.petroldriver.com and our YouTube channel [PetrolPostDriver](https://www.youtube.com/channel/UC...).

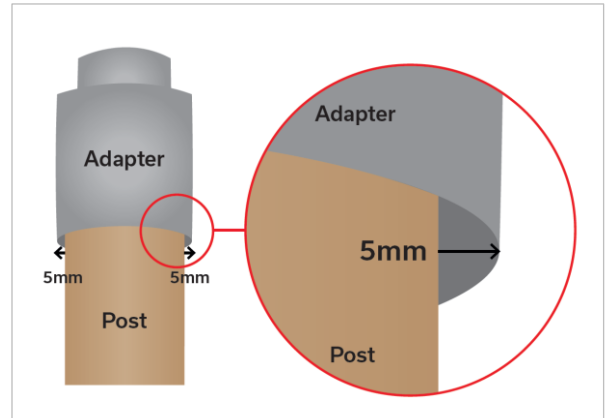

Tall posts



Warning: Driving posts that are significantly taller than the operator may result in over reaching when positioning the Post Driver. This may result in injury to the operator and may result in damage to Post Driver.



Solution: Extension Handles are available as an accessory. These attach to the bottom (or the top to prevent bending over) of the Post Driver and prevent over-reaching. (Product Code; LONGHANDLE)



Specification and Applications

Design and function

The Christie Post Driver / Easy Petrol Post Driver was designed for driving steel fence pickets (star/Y or T pickets) into the ground. A range of other materials can be driven, however, success and performance will depend on the quality of the material used and the ground conditions.

The Post Driver operates a pneumatic hammer system with a Honda GX35 engine to drive material into the ground with the hammering action.

Specification

Machine model	CHPD78-1
Engine model	Honda GX35T 4-Stroke
Blows per minute	1720
Joules	26
KW / hp	1.0 KW (1.3HP) at 7,000 rpm
Vibration levels	9.24 m/s ² (Data from 100mm diameter wooden post)
Fuel consumption	0.71 L/h at 7,000 rpm
Starting system	Recoil (pull start)
Weight	15.3kg (dry)
Noise level	>100dB Hearing protection required

Applications

Types of posts

The Post Driver will drive a wide range of posts, the below table is not exhaustive but provides a guide to what applications this machine is suitable for. Some applications require additional accessories.

Post
Timber round stakes up to 100mm (4") diameter
Timber square stakes up to 80x80mm
Hollow Pipe up to 76mm diameter (e.g. scaffold poles or heating pipe)
Square steel sections and angle, up to 50mm square / 76mm diameter
Marquee Pins up to 50mm Mushroom Head
Spiral Anchors up to 50mm Hex Head
Vineyard Posts & Ground Anchors
Earth rod stakes
Standard star/Y or T pickets and posts - diameter up to 100mm
Clipex® Beefy® & Standard Posts
Waratah® Gripfast® Trellis Posts & Galstar MaxY® posts

Ground conditions

The Post Driver has excellent performance in most ground conditions. Small to medium stones will generally displace. If a larger stone is struck and the post is not progressing, cease driving, remove the post and move along a short distance and retry.

The Post Driver will not drive a post through solid rock. This is beyond the limits of a small, lightweight machine and most posts.

Large Diameter Posts; for posts larger than 85mm diameter a Pilot Hole is sometimes required. This can be achieved by hand using a standard Pointed Steel Bar. This creates a guide for the post and displaces some of the soil, making the work easier for the Post Driver.

Dry or Compacted/Hard Ground; if the ground is very dry, compacted, or hard composition (e.g. clay / chalk) a larger pilot hole may be required for posts larger than 80mm. Use the [Pilot Core Tool](#) to achieve a 50mm pilot hole. Fill this hole with water and leave to soak. This will greatly improve the post driving results.

Operating instructions

Pre-start checklist

Check point	Remedy
Check engine oil Honda GX35	<ul style="list-style-type: none">• Fill to the top thread of the filler while the motor is in a vertical position• ! Overfilling will damage the engine• Refer to Honda Owner's Manual GX35• Use 10W30 mineral engine oil
Check fuel level	<ul style="list-style-type: none">• Fill with regular unleaded fuel only
Visually inspect striker and barrel	<ul style="list-style-type: none">• Look in the receiver guide of the Post Driver to check for damage to the striker or tube, repair/replace if damaged• Dislodge any debris (such as tar, timber picket splinters with a WD spray into the receiver barrel
Visually inspect all fasteners	Tighten as necessary: <ul style="list-style-type: none">• Cover plate screws.• Receiver guide screws.• Screws in engine guard.• Screws in body castings. If screws repeatedly come loose; <ul style="list-style-type: none">- remove screw entirely,- clean both thread and screw with degreaser/solvent- apply Oil Tolerant Locking Compound & re-affix screw (such as Bondloc B243).

Safe starting



- Start and operate the Christie Post Driver unit outdoors, and in a ventilated area
 - Never wrap the Honda GX35 pull starter rope around the hand
 - Do not quick release the Honda GX35 starter grip, guide the starter rope back slowly to permit the rope to rewind properly
 - Failure to observe instructions regarding the pull starter may result in injury to the operator's hand and damage to the starter
- i. Ensure the ground is firm or select a solid surface, in an open well-ventilated area.
 - ii. Maintain good balance and secure footing on both feet, with feet shoulders width apart.
 - iii. Place the Post Driver, resting on the receiver barrel on firm ground with the top handle in left hand to stabilize machine.
 - iv. Turn On/Off switch to On (I). Prime the fuel bulb, and engage the choke.
 - v. Grasp the pull cord toggle; pull up and out. Excessive force or speed is not required.
 - vi. Guide the starter rope back slowly to permit the rope to rewind properly.
 - vii. Once started, dis-engage the choke.
- Should the engine not start easily, or the pull starter offer resistance, refer to the Troubleshooting section.

Driving posts



- Ensure there is plenty of clearance behind and next to the Honda GX35 engine, to allow for the escape of hot and toxic exhaust fumes.
- Only operate the Christie Post Driver in light conditions with good visibility.

Ensure the operator and all other persons nearby wear, at a minimum, the following PPE:

- Class 4 hearing protection, greater than 22dB attenuation
- Safety glasses to AS/NZS1337 medium impact rating
- Gloves suited to manual handling - leather or other abrasion resistant material, anti-vibration gloves are recommended
- Steel capped boots



Driving in a Post

1) Start motor safely as described in *Safe starting*.

Stab the post in the required position into the ground.

- Where many posts are to be driven, doing this in batches will save time.
- A guide wire can be used to assist in maintaining a straight fence line.

2) Lift the Post Driver over and on to the post.

3) Ensure the post is in a vertical position and the Post Driver is on in a parallel plane to the post. Correct alignment is depicted on the safety label on the receiver barrel.

4) Ensure the operator maintains a stable standing position with feet shoulders width apart. Keep the body weight balanced.

5) Pull down on the Post Driver with 10-15kg of downward force.

- This is mandatory to ensure the internal hammer mechanism is engaged in the correct operating position, and reduce unexpected movement while driving.

6) Gently pull the throttle trigger until the hammer action is felt.

7) Once the post has been observed as being driven in to the ground, then fully depress the throttle trigger and drive the post to the desired depth.

- If the post does NOT drive into the ground cease driving, remove the post and move along a short distance and retry.
- ! Never drive a post until the receiver barrel touches the ground.

8) Once the desired depth is reached, release the throttle fully so the Honda GX35 Engine is idling, and the hammer action has stopped.

- ! Never operate the throttle unless the Post Driver is on a post, and between 10-15kg downward force is exerted on the handles.

9) Move to the next post and repeat.

Refuelling



Warning: Fuel vapors are extremely flammable and can cause severe injury or death, if ignited by a spark or excessive heat from a hot motor.

- Always switch off the Honda GX35 engine, and allow adequate time for it to cool down before refueling.
- Use regular unleaded fuel only.
- Fill the tank on level ground avoiding spilling fuel on the motor. Allow any spilt fuel to evaporate before restarting the motor.
- Ensure fuel cap is tightened adequately before restarting the motor.

Maximum Operating Conditions

If driving posts in without stopping and very short duration between posts, there is a chance in hot weather that the machine can temporarily seize.

A maximum of 10-15 minutes of continuous running in 25 degree + ambient temperature will be achievable before seizing. This unfortunately is a limit of the machine and operators may need to rest the machine between posts when driving in hot weather.

Maintenance and servicing



Read the supplied Honda Owner's Manual GX35 and perform engine maintenance as recommended by Honda.



Failure to follow the maintenance schedules for the Christie Post Driver, and Honda GX35 engine, may result in non-warranty machine failures.

Maintenance schedule

Service	Domestic/farm/light use	Commercial/heavy use
Crank lubrication service	Annually	250 hours or 3 months Whichever occurs first
Hammer section service	Bi-annually	500 hours or 6 months Whichever occurs first

End user servicing

A service kit is available to purchase from Easy Petrol Post Driver or any retail distributor, containing grease, spark plug, bolts, locking washers, and all o-rings.



Part Code; SERVICE KIT

Manufacturer servicing

Should assistance be required, Easy Petrol Post Driver can perform servicing at a cost.

For technical advice, please contact Easy Petrol Post Driver or your local stockist.

Crank lubrication service

This service is to be performed at the following intervals;

- annually for domestic/farm/light use,
- 250 hours/3months for commercial/heavy use.

Tools/materials required

- 2.5mm Allen key, of good quality
- Thread locking compound medium strength
- Degreaser solvent
- Mobilux EP1 grease

Performing the crank lubrication service



Figure 1 Cover plate.

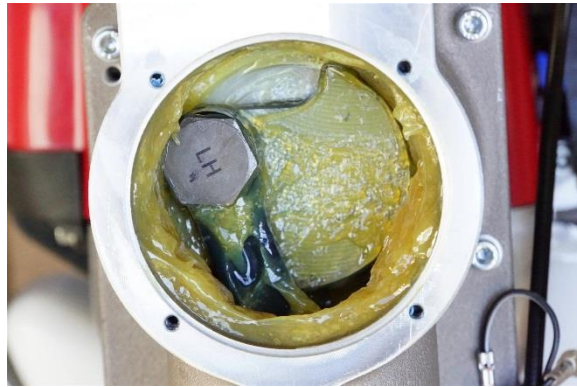

Figure 2 Crank area with sufficient grease. Colour is yellow prior to use as above, and will tend to brown with age and use.

During the servicing process, ensure to remember which orientation each removed part is positioned in the machine. Some pieces must be returned a certain orientation to ensure correct re-assembly.

1. Remove the 4 screws from the crank Cover Plate (CEPD37), using a 2.5mm Allen key.
2. Inspect the amount and colour of grease in the crank area. There should be a liberal amount of grease coated around the outside of the crank about 6-8mm thick.
 - If the grease looks to be low, add a **small amount** of EP 1 grease. 20-30 ml is generally sufficient.
 - There should be a maximum of 75mm grease within this chamber.
 - The colour of the grease can be yellow to brown.
 - If the grease is very dark, this may be due to residue from the posts entering the machine. The Post Driver may will need further stripping as described at Hammer Section (pg12), and is recommended if reduced performance has been noted.
3. Clean the cover plate screws, O-ring and thread holes carefully with degreaser solvent. Apply Oil Tolerant Threadlock Compound, of medium strength (such as Bondloc B243).
4. Replace the o-ring carefully, and align the cover plate. Tighten the cover plate screws in an even pattern, to prevent pinching the cover plate o-ring.



The amount and type of grease used is critical for the performance and service life of the Post Driver. Not enough grease will cause failure and too much grease will affect the striking power of the tool. **Do not over or under grease.**

Hammer section service

This service is to be performed at the following intervals;

- every 6 months for domestic/farm/light use,
- 500 hours/6months for commercial/heavy use.

Tools/materials required

- 2.5mm and 6mm Allen key, of good quality
- 5mm punch for dowels
- Small engineers hammer
- 13/16 (21mm) socket and ratchet
- Thread locking compound medium strength
- Degreaser solvent
- Mobilux EP 1 grease

Performing the hammer section service



Figure 1 CHPD78-1 hammer section

During the servicing process, ensure to remember which orientation each removed part is positioned in the machine. Some pieces must be returned a certain orientation to ensure correct re-assembly.

1. Remove the 8x Allen head bolts joining the bottom guide tube or fitted adapter to the Flanged Adapter section (CEPD 938-1) using a 6mm Allen key, and carefully slide the bottom guide tube from the Flanged Adapter.
2. Remove the 4x Allen head bolts (CEPD M880) from the Cast Bottom Housing (CEPD925) using a 6mm Allen key, and carefully slide the bottom hammer section from the Cast Bottom Housing.
3. Remove the damper section, taking note of the orientation of these pieces, and inspect for wearing on the damper O rings, damper washer, and steel components. The CEPD Damper Washer is machined into the hammer housing (CEPD936-1)
4. If significant wear is seen in the hammer housing (CEPD936-1), the operator may not be holding the driver square on the post – Please see 'Driving in a Post' earlier in this manual.

5. Remove the bottom hammer assembly from the Cast Bottom Housing (CEPD 925). Remove the 3rd Hammer (CEPD 937) using a 6mm punch to carefully push the two retaining dowel Pins (CEPD PIN 8x36) from the Hammer Housing.
 - A vice and some soft jaws may aid in holding the round hammer guide and hammer in place.
6. Inspect the internal Viton O ring seal (BS220) inside the hammer guide for wear or damage, replace if necessary.
7. Inspect the Damper Washer (CEPDDAMPER3MM) for wear. This sits on the Hammer Housing between the Flange Adapter. Replace if required.
 - The 3rd Hammer (CEPD 937) is made from high quality steel and should not be a wearing component, but ensure a visual inspection is carried out after cleaning for wear or damage and replace if necessary.
8. To remove the Top Hammer, gently tap the main Crank Housing (CEPD924) vertically down on a soft bench top and it should slide out of the inner Steel Cylinder Liner (CEPD 24-1).
 - Take note of the orientation of the components as in the parts diagram.
9. If the Top Hammer O-ring (BS222) shows obvious signs of wear, the top piston (CEPD30) can be removed from the crank by:
 - Remove the Cover Plate (CEPD37) to gain access to the crank assembly.
 - Remove the **Left Hand thread** Crank Pin (CEPD 38 PIN) from the crank.
 - Jam the Connecting Rod (CEPD31) with a round metal bar, and gently push the Piston and Connecting Rod through the bottom of the housing using a soft metal rod. **DO NOT USE A SQUARE OR SHARP OBJECT TO JAM THE CONNECING ROD.**
 - Orientation is not critical on the piston or connecting rod.
 - Check the Piston (CEPD 30) and Viton O ring (BS222) for any signs of wear, and replace along with top hammer O ring (BS222) if necessary.
 - Wash all grease from the housing and components using a degreaser solvent and inspect the inner barrels for wear and deep scores.
 - If the Steel Cylinder Liner is scored or too badly worn the entire Post Driver should be sent back to Easy Petrol Post Driver for repair or replacement of the inner liner.

Reassembling the hammer

After thoroughly cleaning and drying the components and checking for excessive wear, reassembly can occur.

1. Apply a coating of the supplied EP 1 grease around the Piston O ring (BS222) and outside of the piston, and gently push back into the housing using a soft dolly.
2. Add a small amount of grease to the Crank Pin (CEPD 38 PIN) and reassemble remembering it is **Left Hand thread**. Do not over tighten this pin; maximum 30Nm.
3. Add a coating of EP 1 Grease to the outside of top hammer, and gently push into the housing. The O ring will be at the top.
4. For the bottom hammer section, slide the Damper Washer (CEPD DAMPER 3MM) back onto the Hammer Housing (CEPD936-1). Then add a light coating of EP1 Grease to the 3rd Hammer (CEPD 937) and push through the flanged adapter (CEPD938-1). Push this into the Hammer Housing (CEPD936-1).
5. Align the two flat faces of the 3rd Hammer (CEPD937-1) with the two holes in the Hammer Housing (CEPD936) for the retaining dowel pins and gently tap the dowels (CEPD PIN 8X36) into place. **Note the dowels can only be driven from one direction.**
6. Reassemble the damper components with a small amount of EP 1 Grease to all components. (CEPD 22/ 20 & 2xBS326).

For the damper assembly:

- Place the hammer housing (CEPD936) on a bench and place one of the damper O rings (BS326) in the cup.
- Place the hammer guide (CEPD 20) inside the cup on top of the first O ring with internal radius facing down. Once assembled the Flat side needs to be to the top of machine. The curved side to bottom of the machine. **This is important** – if assembled incorrectly this could cause damage to the hammer.
- Place the second Damper O ring (BS326) on top of the hammer guide, inside the cup.
- Place the damper washer (CEPD 22) on top of the O ring, ensuring the small diameter spigot is facing up. This spigot aligns inside the cylinder liner.
- Fit the damper assembly in the bottom guide tube over the bottom hammer.



Figure 2 Damper assembly correct alignment

7. Install the bottom guide section back into the main housing and insert handlebars and springs back into the bottom housing in this process, ensuring the thin section O ring is not damaged between the housings.
8. Apply medium strength thread locking compound to the 4 socket screws (M8x80) in the flanged adapter (CEPD938-1) and tighten to 20Nm.
9. Apply medium strength thread locking compound to the 8 guide tube retaining bolts (M8X18) and ensure lock washers are fitted to the screws. Put all screws finger tight into the respective holes and then tighten in an alternate pattern.
10. Apply 75ml of the supplied grease to the crank area, and reinstall the 4 socket screws (M4x10) using medium strength thread locking compound.



All screws must be correctly tightened in an alternate pattern, as machine damage can occur from loose or lost bolts.

Troubleshooting and FAQ

Troubleshooting

Recoil starter offering resistance

- Engine overfilled with oil. Drain out and see fill instructions in the Honda GX35 manual. Place unit on a post so it is upright and level. Fill oil level with filler thread.

Pull starter rope pulling but engine is not cranking

- Damaged recoil starter or starter drive cog.
- Requires replacement part either whole recoil starter or starter drive cog.

Engine does not start

- Check fuel level and quality.
- Check On/Off switch.
- Prime fuel bulb and engage choke.
- Check spark plug and spark present.

Post driver not hammering

- 1. If using tar coated steel or coated timber stakes, residue may be left in the guide tube causing the bottom striker to foul. This can be dissolved by spraying inside the guide tube with a WD spray.
 - Place unit on a post. Lift and give a gentle drop onto the post, this will re-engage the striker. Do not operate unless on a post and exerting 10-15kg downward pressure (pulling down on the handles).
 - If the hammer will not engage after trying WD spray procedure, further servicing of the machine may be required as in previous chapters.
- 2. Mud clogging the hammer section. Remove adapter & clean out any foreign bodies clogging the hammer. Hammer section service may be required.

Loss of power when pressing throttle

- Dirty or stale (old) fuel. Empty all fuel, start engine & run until it cuts out. Refill with fresh fuel.
N.B. Fuel turns stale within 4 weeks of purchase, even if stored correctly. If your engine will be used intermittently (i.e. more than 2-3 weeks between each use) use petrol which has been treated with fuel stabiliser, when fresh.
- If problems persist the Fuel Filter may require changing, and the Carburettor may require cleaning. Also refer to the Honda recommendation page at the end of this manual.
- For periods of un-use (greater than 2-3 weeks) it is recommended to empty the fuel entirely, then restart the engine and allow to run dry. The engine can now be stored indefinitely.

Frequently asked questions (FAQ)

Q: Will servicing void warranty?

A: Warranty will be covered when performed in accordance with the instructions contained in this service manual.

Q: What type of fuel is recommended?

A: Regular unleaded petrol. Refer to the Honda GX35 manual.

Q: What type of Engine oil is recommended?

A: 10W30 mineral engine oil. Refer to the Honda GX35 manual

Q: What type and quantity of grease is recommended for the post driver?

A: Mobilux EP1 grease. Approximately 100ml is sufficient for a total strip and rebuild of the machine as per instructions in this manual.

Q: How often does the machine need stripping and rebuilding?

A: As per the servicing recommendations in this manual, or if there is notice of performance reduction and determined not to be an engine problem.

Q: How long do the hammer components last?

A: The hammer components are made from the highest quality material and are intended to give a long lasting lifespan for this commercial machine when serviced in accordance with the recommended schedule.

Easy Petrol Post Driver Warranty

Conditions

The Easy Petrol Post Driver has a warranty period limited to defects in workmanship or parts, from the date of supply (by the distributor to the end-user) when used in accordance with reasonable use and care. Please keep your proof of purchase to assist with any warranty claims.

Defects that occur within the stated warranty period other than those components excluded below shall be repaired or replaced at the discretion of Easy Petrol Post Driver & Christie Engineering.

Any parts or goods repaired under this warranty is only warranted for the remainder of the warranty period commencing the original date of supply by the distributor.

Condition	Warranty period
Purchase date on or after 01.01.2018	3-years.
Purchase date on or before 31.12.2017	1-year.
Purchased for Hire	1-year.

Exclusions

This warranty does not cover:

- normal wear and tear,
- damage caused by the Customer failing to follow the Safety and Operating Instructions, including but not limited to seizures due to lack of maintenance and cleaning;
- components that may need replacement or repair due to normal wear and tear or lack of maintenance upkeep, including but not limited to:
 - O rings and seals,
 - lost, stripped or broken fasteners,
 - Guide tube (Receiver barrel),
 - Lubrication and grease.
- physical damage caused by accident, misuse, negligence, abuse or fire;
- unauthorised alteration, modification or substitution of any parts of the Post Driver, installation or use of the Post Driver not in accordance with instructions supplied;
- damage due to faulty installation or operation or maintenance;
- overloading or transport damage; or damage as a result of improper packaging,
- Post Drivers that have their serial number or model number label removed or defaced;
- failures or defects cause by or associated with use of the Post Driver in unsuitable physical or operating environment;

- damage caused by force majeure events such as acts of God and factors beyond reasonable human control;
- Post Drivers that have been used for a purpose other than for what was reasonably intended for the Post Driver,

To the extent permitted by law, where the Company determines in its sole discretion that the warranty claim does not fall within the terms and conditions of this warranty and is not accepted by the Company, the Company is not required to repair or replace the Goods and is not liable to the Customer for any costs or expenses incurred. The Customer must, at its own cost, retrieve the Goods from the Company's premises or if the Company agrees, the Company will arrange for return of the Goods to the Customer at the Customer's cost.

How to make a claim:

If the defect has appeared within the warranty period of supply by the distributor subject to the terms above, the consumer is entitled to claim a warranty. To make a claim the consumer must:

1. Immediately cease using the Goods as soon as the Customer suspects there is a fault;
2. Contact Easy Petrol Post Driver (a trade name for SPA Landscaping Limited) on 0044 (0) 114 2699119 or at info@petrolpostdriver.com and provide details of the fault and details of purchase (invoice number & serial number) to obtain technical support;
3. If technical support does not rectify the fault and the warranty claim is accepted by the Company, the Company will provide a return number for the consumer to return the product, at the customer's own cost, with the details of the fault and any other details requested by the Company to the following address:

Easy Petrol Post Driver

22 Orgreave Close, Sheffield, S13 9NP, ENGLAND

4. Ensure the product is packaged in a way that will not cause damage to the product during transport.

Extent of Warranty

Unless the fault with the product/good is major and the provisions of The Act apply. The Company may, but is not obligated to, at its sole discretion reimburse the Customer for any reasonable delivery costs incurred in sending the Goods to the Company if the warranty claim is accepted by the Company.

Conditions

The following warranty conditions are valid for machines sold to customers from 1 January 2012. For engines on the market before 1 January 2012 different warranty conditions apply. Please contact your nearest dealer on the **SERVICE NETWORK** (see below) for more information.

Warranty period in months

Engine Code	Non-commercial use	Commercial use Rental use
GX25 / GX35 / GXH50 / GXV50 / GXV57-engines	24	12

Commercial use is considered to be when the machine is purchased by a company. In cases where the machine is sold to another private person, the warranty lapses.

Exclusions

Please see the following website for Warranty Exclusions:

<http://www.honda-engines-eu.com/web/eec-public-site/warranty-exclusions>

How to make a claim

In case you face a problem with the Honda engine on your machine, you can claim a repair or replacement under warranty if the following conditions are fulfilled:

- The problem is related to a manufacturing defect on the engine.
- The engine is within the warranty period (see above **Warranty Conditions**).
- The problem does not fall within the **Warranty Exclusions** (see above).

Procedure and rules:

- Go to www.honda-engines-eu.com
- This website includes the **SERVICE NETWORK** and **SPARE PARTS DIAGRAMS**.
- Using the **SERVICE NETWORK** selection, find your nearest dealer who offers **Warranty Handling**.
- Contact the dealer to discuss the problem.

- Authorized dealers are directly linked to the Honda subsidiary or distributor in your country.
- Independent dealers can forward your claim to a spare parts distributor or to the Honda distributor presuming that those are available in your country.
- If there is no Honda subsidiary or distributor in your country it is recommended to contact the dealer, importer or manufacturer of the machine in order to claim warranty.
- The invoice or another document proving the date of sales of the machine should be presented.
- In case of export, the warranty conditions of the country where the machine is imported are valid (not those of the country where the machine is produced).
- Honda Warranty applies on all Honda products.
- Honda General Purpose engines are used to power machines that are manufactured and sold by other companies than Honda.
- In this case the Honda warranty is only covering defects of the engine, not of the machine where it is incorporated into nor on the parts or equipment that are attached to the engine in order to fit the engine to the application.
- If you experience difficulties with making a claim, please contact the Dealership you purchased your Easy Petrol Post Driver from.

For full information on Honda Warranty please go to the Honda Engines website:

<http://www.honda-engines-eu.com/web/eec-public-site/warranty>

Problems caused by stale petrol can be avoided by following these simple tips.

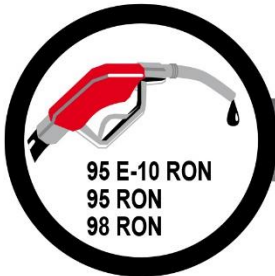

WHICH KIND OF PETROL SHOULD YOU USE?

- Regular unleaded 98, 95, 95 E5 or E10 can be used in **Honda** products (E5 or E10 contains 5% or 10% ethanol).
- Do not use any petrol containing more than 10% ethanol. This will cause corrosion damage to fuel system components.
- **Honda** does not anticipate any negative effects from the use of Alkylate type petrol. However, due to the availability of different Alkylate fuels, no recommendation for their use can be provided at this time. Please refer to the instructions and data sheet provided by the Alkylate manufacturer for more information.
- If your **Honda** product is used intermittently (eg more than 4 weeks between each use) use petrol treated with fuel stabiliser, at the time of purchase.
 - > **Honda** fuel stabiliser has a shelf-life and its performance will deteriorate over time. Once the bottle is opened, it has a maximum life of 2 years.
 - > Fuel stabiliser will not reconstitute or reinvigorate stale petrol. It must be added when the petrol is fresh.



HOW SHOULD PETROL BE STORED?

- Petrol will start to deteriorate if stored for more than 1 month.
- Add **Honda** fuel stabiliser to fresh petrol which is likely to be stored for more than 1 month.
- Only use clean, sealed, approved fuel containers, designed to specifically carry or store petrol.
- If petrol is stored in a steel container (eg a jerrycan) make sure there is no corrosion on the inside of the container.
- Store petrol in a cool place away from direct sunlight.

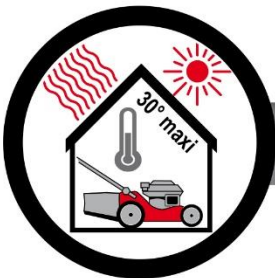

MAINTENANCE OF YOUR PRODUCT.

- If your **Honda** product will be used intermittently (eg more than 4 weeks between each use) use petrol which has been treated with fuel stabiliser, when fresh.
- Turn the fuel tap off, when the machine is not being used.
- Before use, check the engine oil level is correct and ensure the air filter is clean.
- **Before winter storage:**
 - > Drain the petrol from the carburettor and fuel tank (refer to owner's manual for correct procedure).
 - OR
 - > Add fuel stabiliser, which will extend the storage life of the petrol remaining in the fuel tank and carburettor. Fill the fuel tank to the recommended maximum level, using treated petrol. Run the engine for at least 5 minutes to allow treated petrol to enter the carburettor, prior to storage



HONDA RECOMMENDS

HONDA PART NUMBER: 08CXZFSC250

www.honda-engines-eu.com

Distributor Network

Australia, Asia, Rest of World – Manufacturers



Address: Christie Engineering, 123 Delaware Road, Horsley Park, NSW 2175, Australia
Tel: 02 9620 1208
Web: www.christieengineering.com.au
Email: enquiries@christieengineering.com.au

Europe



**PETROL
POST DRIVER™**

Australian Engineering by Christie

Address: Easy Petrol Post Driver,
22 Orgreave Close, Dore House Industrial Estate,
Sheffield, S13 9NP, Great Britain (by care of SPA Landscaping Ltd)
Tel: 0114 269 9119
Web: www.petroldriver.com
Email: info@petroldriver.com
Company Registration: 04240438
Vat Registration: 390 9920 20

North & South America



Address: RediDriver, 16408 S Curtis Road, Cheney WA 99004, USA
Tel: (509) 235-2780
Web: www.redidriver.com
Email: info@redidriver.com



CHRISTIE
ENGINEERING

123 Delaware Road Horsley Park NSW 2175
Ph/Fax: 02 9620 1208
ABN 56 002 534 474
Web: www.christieengineering.com.au
Email: enquiries@christieengineering.com.au

EC Declaration of Conformity

In accordance with

EC Machinery Directive 2006/42/EC (Annex IIa)

We Christie Engineering Pty Ltd
Of 123 Delaware Road, Horsley Park, NSW, Australia 2175
Declare that Christie Post Driver
Type: CHPD
Model: 1

In accordance with the EC Machinery Directive 2006/42/EC and has been designed and manufactured to the following relevant harmonized EN Standards –

EN 292 Safety of machinery – Basic concepts, general principles of design
EN 1050 Safety of machinery – Principles of risk assessment

If this equipment is modified without the agreement of the undersigned, this declaration becomes invalid.

Peter Christie

AUTHORISED PERSON

Manager

POSITION IN COMPANY

P. Christie

SIGNATURE

13/10/11

DATE/PLACE OF COMPANY



123 Delaware Road Horsley Park NSW 2175
Ph/Fax: 02 9620 1208
ABN 56 002 534 474
Web: www.christieengineering.com.au
Email: enquiries@christieengineering.com.au

EC Declaration of Incorporation

In accordance with

EC Machinery Directive 2006/42/EC (Annex IIB)

We Christie Engineering Pty Ltd
Of 123 Delaware Road, Horsley Park, NSW, Australia 2175
Declare that Christie Post Driver
Type: CHPD
Model: 1

In accordance with the EC Machinery Directive 2006/42/EC and has been designed and manufactured to the following relevant harmonized EN Standards –

EN 292 Safety of machinery – Basic concepts, general principles of design
EN 1050 Safety of machinery – Principles of risk assessment

The machine must not be put into service until the machine is fitted with appropriate drives and has been declared in conformity with the provisions of the Directive.

If this equipment is modified without the agreement of the undersigned, this declaration becomes invalid.

Peter Christie

AUTHORISED PERSON

Manager

POSITION IN COMPANY

P. Christie

SIGNATURE

13/10/11

DATE/PLACE OF COMPANY

CERTIFICATE OF CONFORMITY FOR MACHINE SAFETY

Report No. : 110525
Machine : Christie Post Driver
Serial No. : 001
Model : -
Date of Manufacture : 2010
Manufacturer : Christie Engineering Pty Ltd
Supplier : N/A
Assessment Date : 25th May 2011
Relevant Standards : AS4024.1-2006 Safety of machinery

Based on the evidence presented, Plant Safety Solutions Pty Ltd, (EC Conformity Assessment Body No. 929 and NATA accreditation No. 14155) certify that the machine identified above is capable of conforming with the relevant parts of AS4024.1-2006 Safety of machinery.

NATA Authorised signatory:

ROGER LIM, MIEAust, CPEng, CPMSIA
Principal Consulting Engineer
Plant Safety Solutions Pty Ltd
(Trading as RiskPlant)



[This document is issued in accordance with NATA's accreditation requirements.](#)

NATA Accredited (No. 14155)
Inspection Service
EC Designated Conformity Assessment Body (NO. 929)

Issued date: 25th May 2011



**PETROL
POST DRIVER™**

Australian Engineering by Christie

**Easy Petrol Post Driver
(c/o SPA Landscaping Limited)
22 Orgreave Close
Dore House Industrial Estate
Sheffield
S13 9NP, Great Britain**

Tel: +44 (0)114 269 9119
Web: www.petrolpostdriver.com
Email: info@petrolpostdriver.com

**Registered in England. 04240438
Vat Registration. GB 390992020**